



Government of West Bengal
Office of the Principal
College of Medicine & Sagore Dutta Hospital
Kolkata – 700058; Phone: 033-25239058. Fax: 033-25239057
Website: www.cmsdh.edu.in; e-mail: principal.sdmch@gmail.com

Memo No

Dated

**e-TENDER NOTICE (2nd Call) for procurement of different items for ICMR funded project
(Submission of Bid through NIC e- tender portal)**

NIT No CMSDH-20/2021-25

The Principal College of Medicine & Sagore Dutta Hospital, Kolkata – 700058, is inviting etender on behalf of the Health & Family Welfare Department, Government of West Bengal for obtaining the rate of equipment as per list from bonafide supplier.

Serial No	Name of equipment	Quantity	Earnest Money
1	Precision Guided Radiation Mechanism	01	2% (Two Percent) Tender value
2.	Clinical Stem Injector		
3.	High Pressure fluid jet setup for debridement of ulcer		
4.	Human Machine Interface Equipment		

The supplier will supply the fabricated product with materials and design as mentioned in the specification for the Serial No 1 to 3 & for Serial No 4 items mentioned in the specification required to supply.

1. General Instructions:

In the event of e-filing, intending bidder may download the tender documents free of cost from the website: <http://wbtenders.gov.in> directly with the help of Digital Signature Certificate or from the Health & Family Welfare Department's website www.wbhealth.gov.in.

2. Submission of Bids:

Both Technical Bid and Financial Bid are to be submitted concurrently duly digitally signed, in the website <http://wbtenders.gov.in>. All papers must be submitted in English language.

3. Time Schedules:

The time schedule for obtaining the bid documents, pre bid meetings, registration with the tendering authorities, the submission of bids and other documents etc. will be as per **the list provided in clause no 19** as given below.

4. Eligibility for Quoting:

Basic rate will be quoted in India Rupees including installation charge, GST, Other charges and taxes as applicable.

5. Submission of Tender:

The tender is to be submitted in Two Bid System (Technical Bid or Bid A & Financial Bid or Bid B).
Cover A: File containing Technical Bid only - single file with multiple scanned pages containing Statutory and Non Statutory documents separately.

(A) Statutory Cover containing the following documents:

Essential requirements of the Tendering Firm for participation in the tender & should contain all papers mentioned herein -

- b. Duly filled in CHECK LIST in the prescribed format. Page number of documents must be mentioned in the check list at the time of uploading the LIST, failing which disqualification of tender may be imposed.
- c. Application in the prescribed format, duly filled in & signed in, given in Annexure I
- d. Income Tax Returns submitted for the Assessment years 2021-22, 2022-23 & 2023-24
- e. Trade License in the name of participating firm
- f. Technical specifications of Instrument (in PDF/Excel format. Must mention Make, Model, exact features of the offered item against each point given in the specification chart). **Improper filling &/or suppression of facts/false statement will lead to disqualification and penalty in the form of permanent black listing.**

(B) Non-statutory Cover containing the following documents:

- a. Certificates -
 - 1. PAN Card
- d. Financial Info -
 - 1. Audited P/L & Balance sheet of 2021-22, 2022-23 & 2023-24

COVER "B": Separate file containing financial document only.

- (a) Financial Bid: **BOQ in INR (in excel sheet) should be** basic rate of equipment including of installation, commissioning, carrying, taxes(as applicable)

6. Evaluation of Tender:

During tender evaluation process, "Bid A" will be opened first. Those tenderers who would qualify the essential & other requirements on the basis of technical and commercial documents will be identified and only their "Bid B" i.e. financial bid will be opened. Bidders have to give demonstration for the product and demonstration will be performed at this intuition. Tender inviting authority will fix up date and time demonstration. No addition cost will be entertained for demonstration purpose.

7. Earnest Money:

The amount of Earnest Money to be submitted shall be **2% of tender value**

The process may be followed as per memorandum of the Finance Department Audit Branch bearing Memo No-3975-F(Y) dated: 28th July, 2016 (GRIPS)

The earnest money of the tenderer is liable to be forfeited if the tenderer withdraws his tender as a whole or for any particular item or items at any stage after opening of the tender or fails/refuses to enter into written agreement for any or all of the items of his accepted bid within the time specified when requested to do so or fails to furnish Performance Bank Guarantee within the stipulated time. EMD should reach the office of the u/s along with hard copy of Bid A on or before the stipulated date as mentioned in clause 19.

8. Order & Supply:

The tendering authority has the liberty to ask for performance demonstration of any item before placing order for supply. In case of dissatisfaction, the authority will have the right to disapprove the offer of L1 bidder. The successful tenderer will have to supply within the specified time schedule that had been assured at the time of selection as supplier.

9. Withdrawal /Cancellation & Purchase Policy of Tendering Authority:

The tendering authority reserves the right to withdraw any item from the tender at any stage. The selection of such item, if already made in favour of any tenderer, shall be treated as cancelled. Withdrawal of tender or any revision after submission of tender by the tenderer will not be allowed.

11. Guarantee / Warranty Period:

- i. The machine/Instrument should be covered by free on-site comprehensive Warranty for 3 years after successful completion of installation.
- iii. Breakdown call must be attended with 72 hours of call log.

12. Delivery, Installation and Commissioning

- i. Delivery of the goods at the purchaser's premises shall be completed by the Supplier in accordance with the terms specified by the purchaser.

with the order.

iii. All items are to be delivered within 2 weeks from the date of placement of order.

iv. In case of distributor, the firm should be direct distributor of manufacturing unit. **Sub distributor authorization by distributor will not be accepted at all.**

13. Agreement:

On a tender being accepted, intimation of acceptance will be forwarded to the tenderer by Principal, College of Medicine & Sagore Dutta Hospital, Kamarhati. After communication of the same, the tenderer and the selected distributor (in the event of distributor to receive order and payment in his name) will have to execute agreement in the prescribed form with the Principal, College of Medicine & Sagore Dutta Hospital, Kamarhati

14. Payment Terms:

Payment will be made by e-pradan system after execution of due supply and successful installation and commissioning as ordered, subject to :

i. Submission of Performance Bank Guarantee in terms of **Clause 16** and subject to penalty clause in terms of **Clauses 14**.

ii. Supply of the materials as per specification as provided in the tender documents and the catalogue. Supply of the materials must be made within the stipulated period as specified in the work orders.

iii. On being selected, the successful vendors will have to submit one application to the Principal, College of Medicine & Sagore Dutta Hospital, Kamarhati and concerned procuring authorities stating the name of the payee/recipient, Bank account no with MICR code, IFSC of the payee/recipient for making e-payment. Payment will only be released after satisfactory installation and commissioning and verification of necessary documents for making payment.

15. Dates & Information:

S. No	Items	Dates
1	Date of uploading of N.I.T. Documents (online) from this end	20.03.2025
2	Documents download start date (Online)	20.03.2025
4	Bid Submission starting (On line)	20.03.2025
5	Bid Submission closing (On line)	07.04.2025
6	Bid opening (Technical)	09.04.2025
7	Date of uploading list for Technically Qualified Bidder (online)	Notified later
8	Date for opening of Financial Proposal (Online)	Notified later
9	Date of uploading of list of bidders along with the approved rate	Notified later

Principal, College of Medicine & Sagore Dutta Hospital, Kolkata reserves the right to change the above schedule in case of any exigencies after putting up a notice in the departmental website and Notice Board of College of Medicine & Sagore Dutta Hospital, Kolkata.

16. Validity of Tender:

i. Rate of tender will remain valid for 1 year.

iii. During the scrutiny, if it comes to the notice to tender inviting authority that the credential or any other paper found incorrect/ manufactured/ fabricated, that bidder would not be allowed to participate in the tender and that application will be out rightly rejected without any prejudice.

Principal

17/03/25

College of Medicine & Sagore Dutta Hospital,
578, B T Road, Kolkata – 700058

CHECK LIST (MUST BE PROPERLY FILLED)

S. No	Item	Pl put tick or cross as applicable	Page Number
1	Application submitted in Annexure I		
2	Copy of PAN Card of the authorised signatory		
3	Document of submission of EMD.		
4	Manufacturing License of the Product or Products		
5	GST Registration certificate		
6	Last 3 Assessment years' returns of Income Tax i.e. for 2021-22, 2022-23& 2023-24		
7	Last 3 financial years' P/L Balance sheet, ie. For the year 2021-22, 2022-23& 2023-24		
8	Affidavit of non-conviction affirmed before Judicial Magistrate/Executive Magistrate (affidavit sworn after 01.01.2025)		

Annexure I

APPLICATION FORMAT

(To be furnished in the Company's official letter pad with full address and contact no etc)

To The Principal, College of Medicine & Sagore Dutta Hospital, Kolkata-700058.

Sub: Tender for **procurement of different items for ICMR funded project**

Sir,

Having examined the documents published in the N.I.T, I /we hereby submit all the necessary information and relevant documents for evaluation:

1. That the application is made by me / us on behalf of.....

In the capacity of.....duly authorized to submit the offer. The authorization letter from the Company is attached in Annexure II.

2. We accept the terms and conditions as laid down in the NIT mentioned above and declare that we shall abide by it for throughout the tender period and its extensions, if any.

3. We are offering rate for the following item /items and assured supply to the Health & Family Welfare Department, Government of West Bengal as per Table-1 (Instrument Specification)

4. a. We propose that the order and bill should be raised in our name.

For liasing, we have appointed M/S having its office at (Address, contact no and e mail address) as C&F agent /Liasoner /Contact person/..... Others (strike out whichever is not applicable) as per clause of the NIT

OR

b. The agreement between ourselves and the distributor/C&F/Liasoner& other documents as prescribed is attached in annexure III

5. In the event of being selected, supply will be made within the stipulated period excepting the condition which is beyond our control.

6. We understand that:

(a) Tender Selection Committee/ H&FW Dept can amend the scope & value of the contract bid under this project.

(b) Tender Selection Committee/ H&FW Dept reserves the right to reject any application without assigning any reason.

Date :-

Contact Details:

Mobile No:

Email:

Signature of applicant including title and capacity in which application is made.

Design and schematic diagram of the equipment:

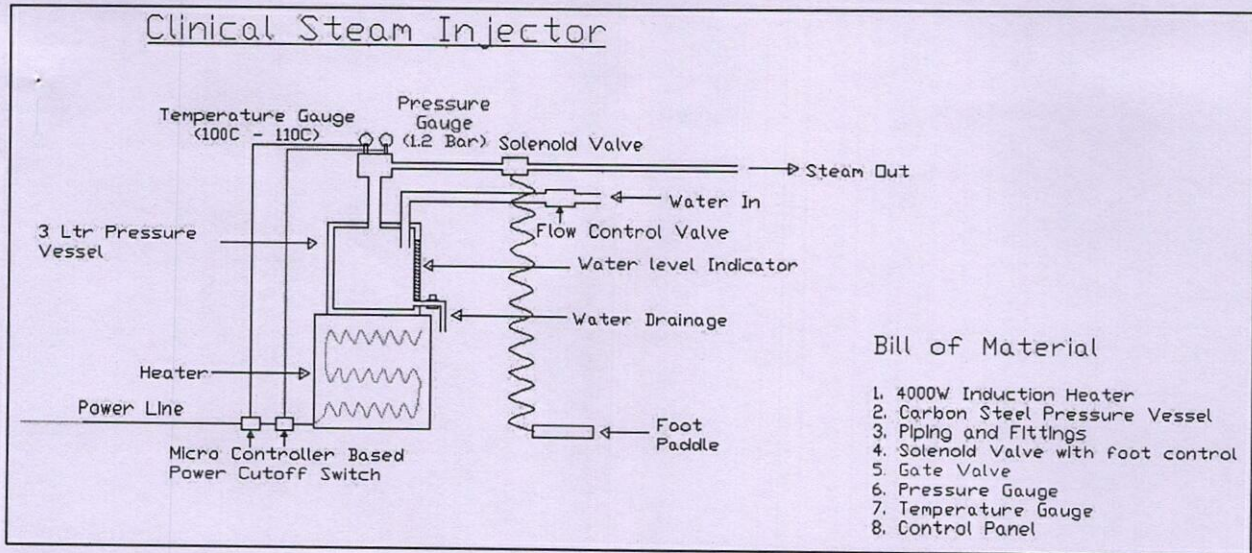

Sl. No.	Components	Quantity
1	4000W Induction Heater	1
2	Carbon Steel Pressure Vessel of size 1 Cubic ft.	1
3	Solenoid Valve with foot control	1
4	Gate valve	1
5	Pressure Gauge	1
6	Temperature Gauge	1
7	Control Panel	1
8	Pipings and Fittings as required for fabrication of the equipment.	As req.

Clinical Steam Injector

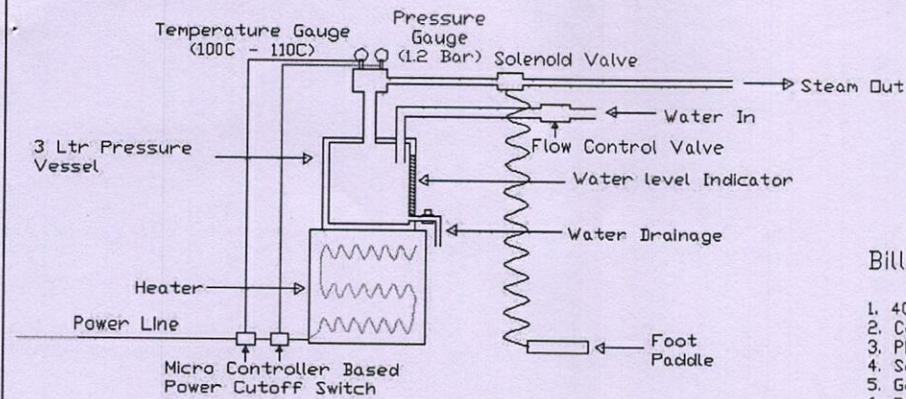

Bill of Material

1. 4000W Induction Heater
2. Carbon Steel Pressure Vessel
3. Piping and Fittings
4. Solenoid Valve with foot control
5. Gate Valve
6. Pressure Gauge
7. Temperature Gauge
8. Control Panel

Sl. No.	Components	Quantity
1	4000W Induction Heater	1
2	Carbon Steel Pressure Vessel of size 1 Cubic ft.	1
3	Solenoid Valve with foot control	1
4	Gate valve	1
5	Pressure Gauge	1
6	Temperature Gauge	1
7	Control Panel	1
8	Pipings and Fittings as required for fabrication of the equipment.	As req.

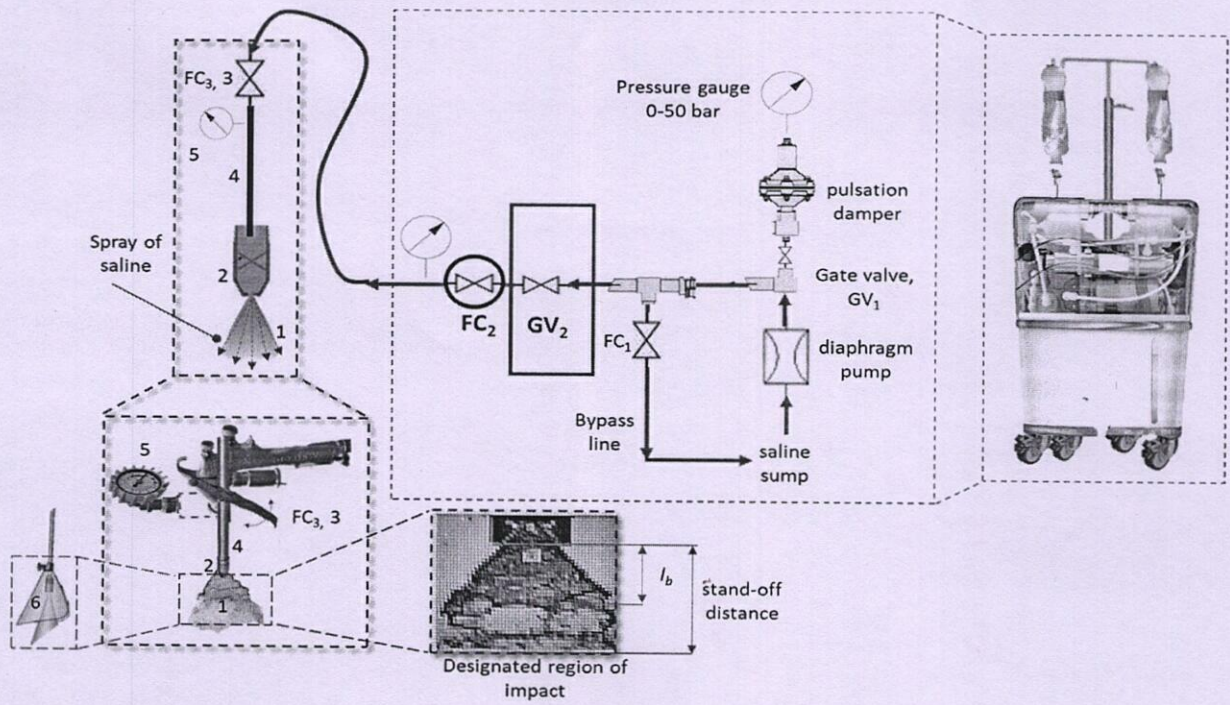

Sl. No.	Item Description of Device Components	Quantity
1.	CPU SR20, AC/DC RELAY, 12DI/8DO	1
2.	ANALOG I/O SM AM06, 4AI/2DO	1
3	HMI 7 INCH	1
4	VFD FOR PUMP	1
5	CONNECTOR	1